

# Presona LP 40 OH



## LP 40 OH

A hydraulic horizontal baler developed for efficient waste paper handling for the packaging and printing industry. The baler has a very compact design and is extremely spacesaving thanks to its tying device with curved strapping needles. The hydraulic unit with oil tank is mounted directly onto the baler. Connection to electrical mains supply is easy - no need for expensive electrical installations - the motor control center of the LP 40 OH is complete with fuses and switches. The main cable is simply connected to your mains supply.

## Function

The material can be fed to the LP 40 OH either by means of a pneumatic conveying system or by a feeding conveyor. A photocell system in the feed hopper controls the material flow and the press operation.

## Strapping

The LP 40 OH is equipped with a fully automatic horizontal strapping unit with four strapping wires. Needles and twisting unit are working hydraulically and are driven from the main hydraulic unit. The wire brake always makes sure that the wire knots are placed on the short sides of the bale, reducing the tension on the wires and preventing the knots from unwinding.

Another important advantage with the wire pulling system is the the wire ends can be kept extremely short (25 - 30 mm), which of course have a favourable effect on wire costs. The bale length is adjustable from the main control panel - bale length can be set from 50 mm and up.

## Design

The LP 40 OH is made entirely of steel. The main parts of the baler are the friction channel with an adjustable friction flap, bale length monitor, main press (without knives), main press cylinder, feed hopper with photocell system, strapping unit, hydraulic unit with tank, pumps and valves and the motor control center with control panel.

## Serviceability

All safety panels and gates have big inspection doors. All Presona balers are manufactured according to the requirements of the CE regulations.

## Safety

Safety first - all moving parts are covered by safety panels and gates, effectively preventing accidental contact. Panels and gates are equipped with safety switches, immediately turning the machine off and stopping all movements when a panel or gate is opened. Emergency stop buttons are strategically placed throughout the baler.



As part of our continuing product improvement, specifications are subject to change without notice.

 **Presona**<sup>®</sup>  
A Member of the Tomra Group

# Presona LP 40 OH

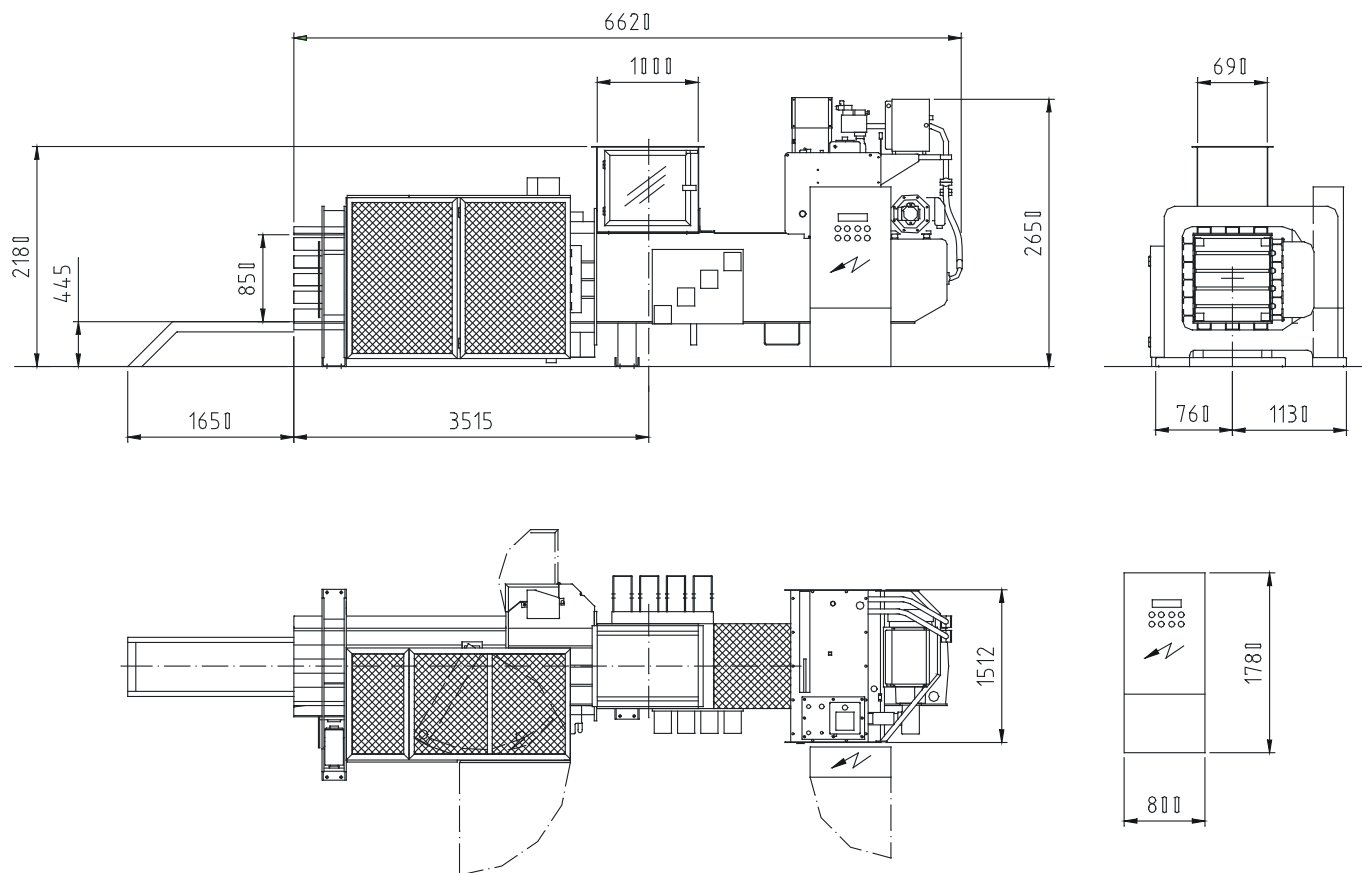

Technical Data		LP 40 OH1	LP 40 OH2
Max volume capacity under load	m <sup>3</sup> /h	100	250
Weight capacity at a specific material weight in the press chamber of			
25 - 30 kg/m <sup>3</sup>	ca t/h	2,5 - 3,0	6,0 - 7,5
30 - 40 kg/m <sup>3</sup>	ca t/h	3,0 - 4,0	7,5 - 10,0
Feed opening L x B	mm	1000 x 690	1000 x 690
Press chamber volume	m <sup>3</sup>	0,77	0,77
Bale size B x H	ca mm	750 x 850	750 x 850
Bale length (variabel)	ca mm	1300	1300
Bale density	ca kg/m <sup>3</sup>	300 - 400	300 - 400
Number of horizontal strapping wires	pcs	4	4
Press force	t	40	40
Specific pressure	kp/cm <sup>2</sup>	6,4	6,4
Max oil pressure	kp/cm <sup>2</sup>	200	200
Oil tank volume	l	600	600
Electric motor (400 V 50 Hz)	kW	15	30
Machine weight	ca t	7,6	8,2

Performance rates and bale densities are subject to moisture content, material pre-bale densities, feed rates and other variables in baling. As part of our continuing product improvement, specifications are subject to change without notice.

**Presona**  
A Member of the Tomra Group